

DTC	P1782	Transfer L4 Switch Circuit
------------	--------------	-----------------------------------

CIRCUIT DESCRIPTION

The ECM receive signal L4 from the indicator switch (LOW switch).

DTC No.	DTC Detecting Condition	Trouble Area
P1782	When driving under conditions (a) and (b) for 1.8 seconds or more, the indicator switch (LOW switch) is ON . (1-trip detection logic) (a) Output shaft speed 3000 rpm or less (b) Transfer shift position is H	<ul style="list-style-type: none"> • Short in transfer L4 position switch (LOW switch) signal circuit • transfer L4 position switch (LOW switch) • ECM

WIRING DIAGRAM

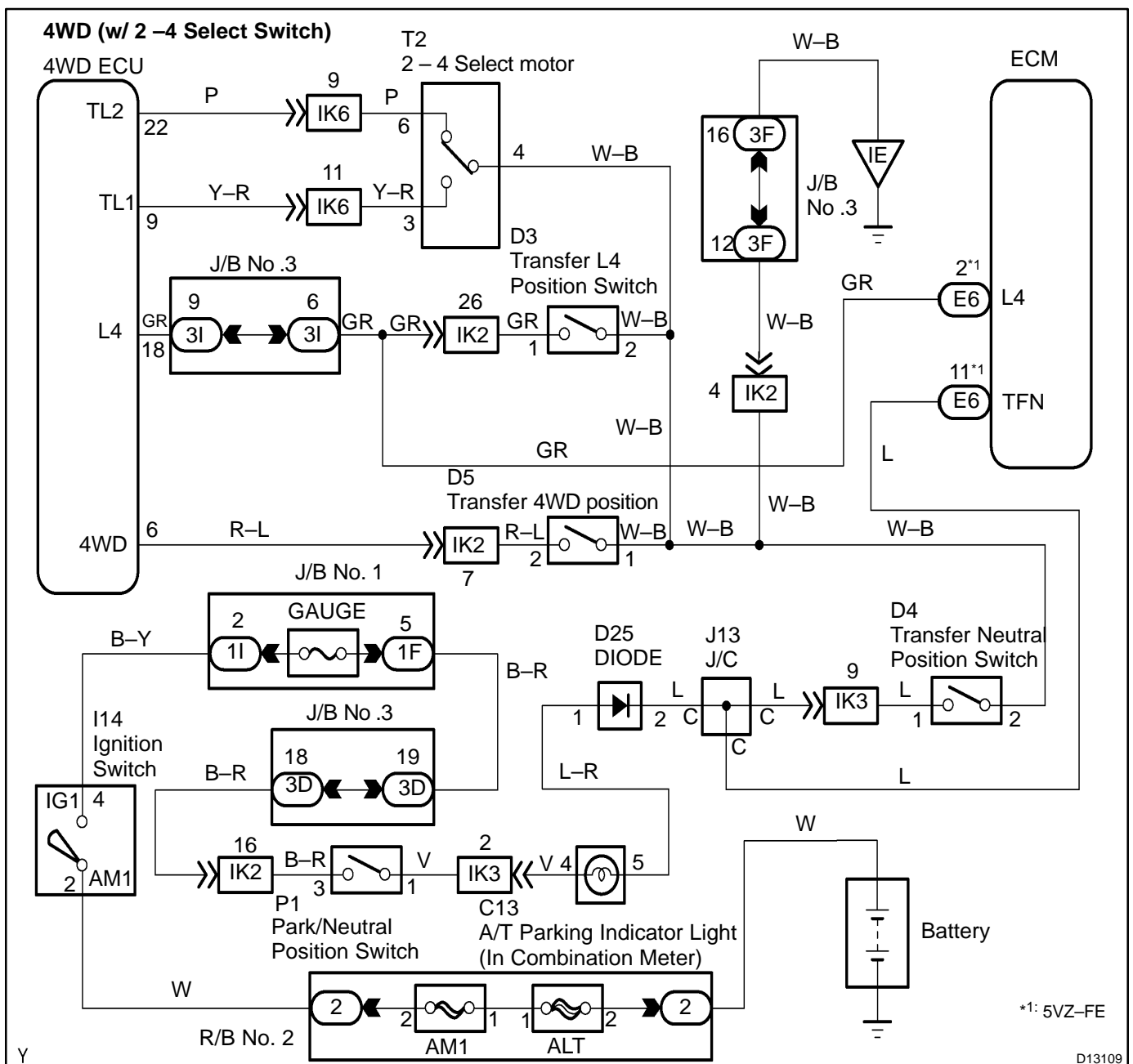

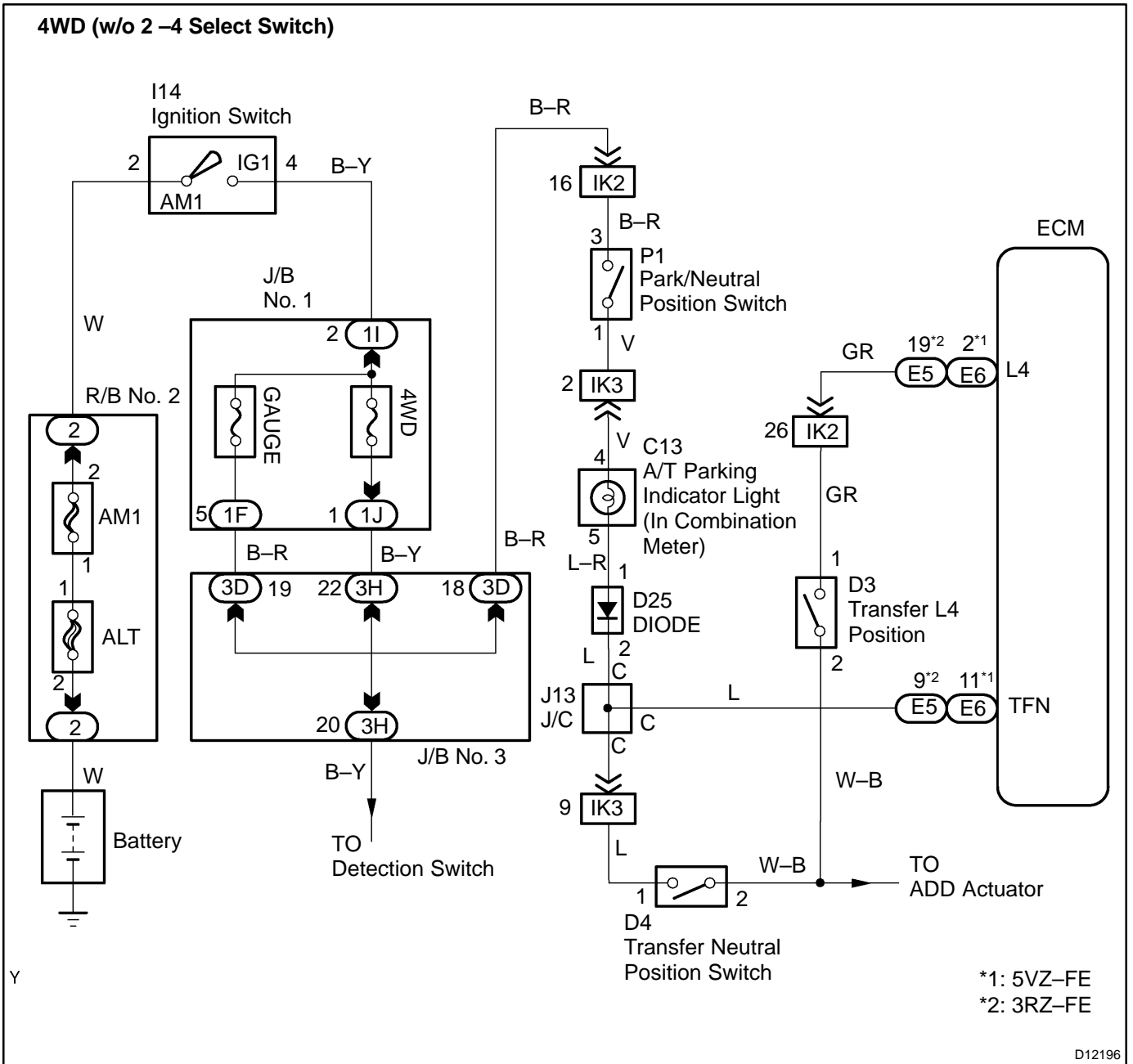

INSPECTION PROCEDURE

1 Check transfer L4 position switch.

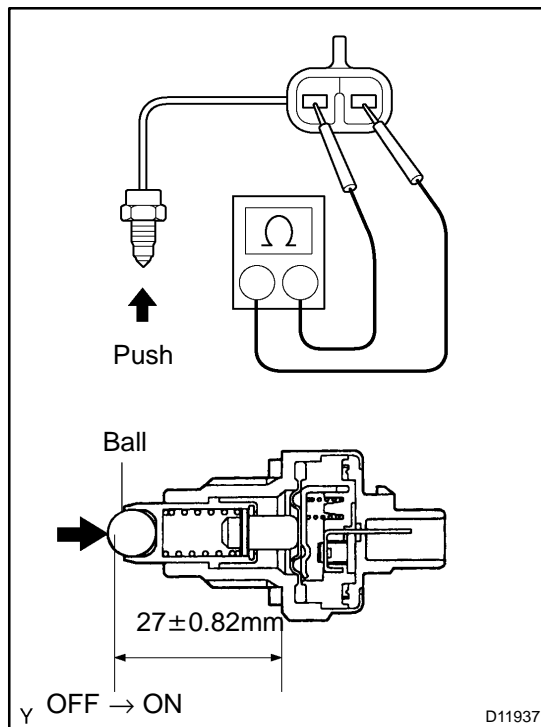
**PREPARATION:**

Remove the transfer L4 position switch (See page [TR-10](#)).

CHECK:

Check that there is continuity between terminals, as shown.

OK:

Switch position	Specified condition
Push	Continuity
Free	No continuity

NG

Replace transfer L4 position switch.

OK

2 Check voltage between terminal L4 of ECM and body ground.

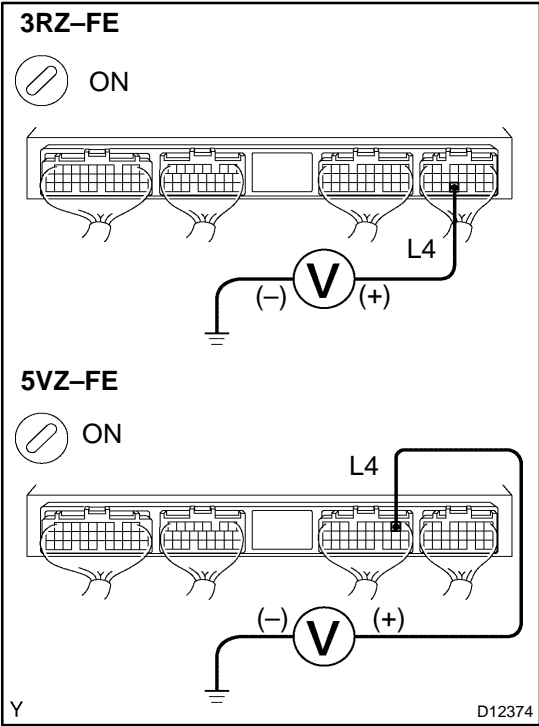

PREPARATION:

Remove the ECM with connectors still connected.

CHECK:

- (a) Turn the ignition switch ON.
- (b) Measure voltage between terminal L4 of ECM and body ground when transfer in L4 position.

OK:

Transfer shift position	Voltage (V)
L4	Below 1.5
Except L4	9 - 14

OK → Check and replace ECM.

NG

3 Check for open or short circuit in harness and connector between transfer L4 position switch and ECM (See page IN-28).

NG → Repair or replace harness or connector.

OK

Check and replace ECM.