

DTC	P0325	Knock Sensor 1 Circuit Malfunction
------------	--------------	---

CIRCUIT DESCRIPTION

Knock sensor is fitted to the cylinder block to detect engine knocking. This sensor contains a piezoelectric element which generates a voltage when it becomes deformed, which occurs when the cylinder block vibrates due to knocking. If engine knocking occurs, ignition timing is retarded to suppress it.

DTC No.	DTC Detection Condition	Trouble Area
P0325	No knock sensor 1 signal to ECM with engine speed 1,200 rpm or more	<ul style="list-style-type: none"> • Open or short in knock sensor circuit • Knock sensor (looseness) • ECM

WIRING DIAGRAM

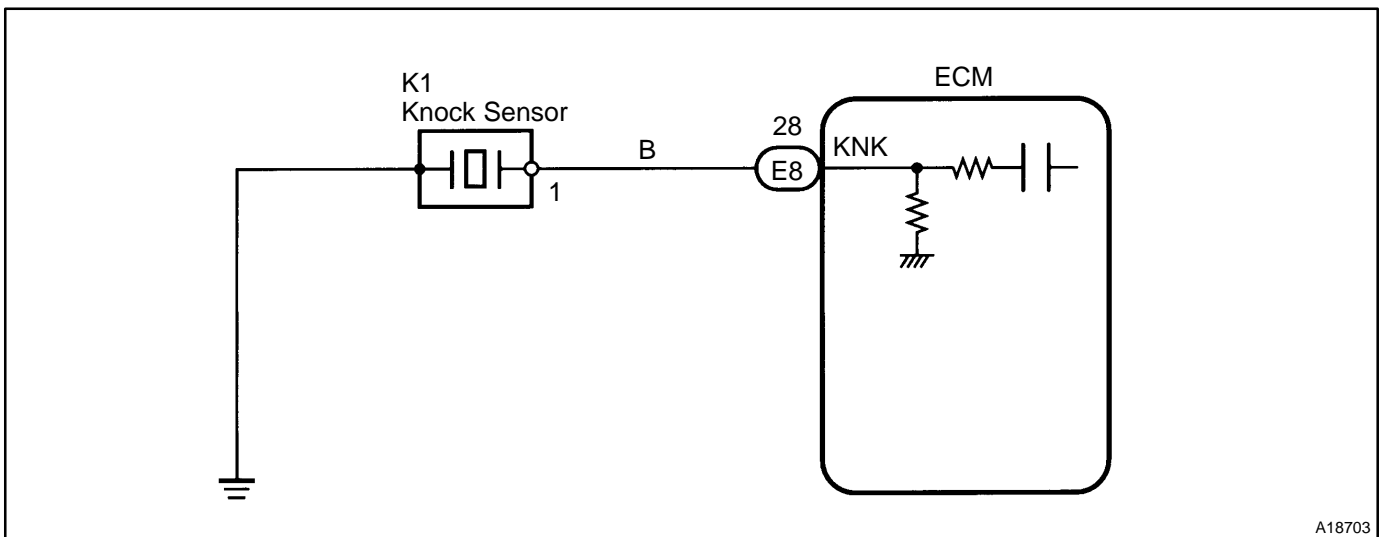

INSPECTION PROCEDURE

HINT:

Read freeze frame data using the hand-held tester or the OBD II scan tool, as freeze frame data records the engine conditions when a malfunction is detected. When troubleshooting, it is useful for determining whether the vehicle was running or stopped, the engine was warmed up or not, the air-fuel ratio was lean or rich, etc. at the time of the malfunction.

1	Check continuity between terminal KNK of ECM connector and body ground.
----------	--

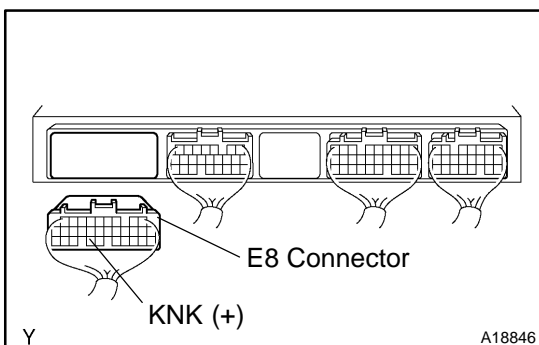

PREPARATION:

- (a) Remove the glove compartment (See page SF-55).
- (b) Disconnect the ECM E8 connector.

CHECK:

Measure the resistance between terminal KNK of the ECM connector and the body ground.

OK:

Resistance: 1 MΩ or higher

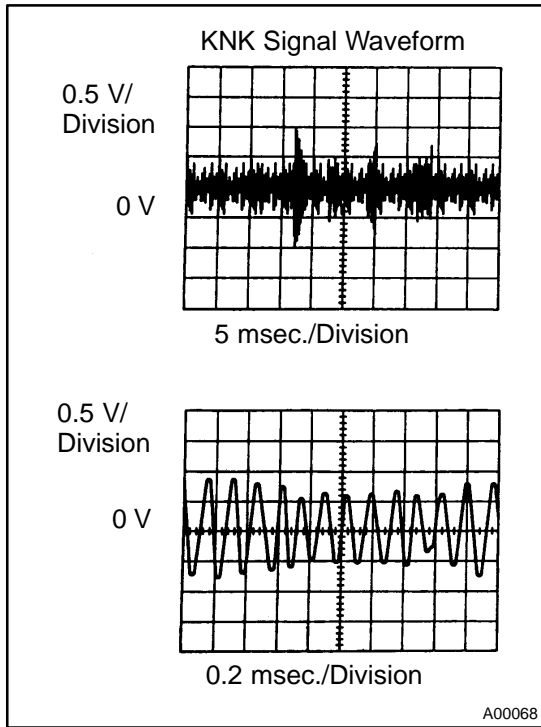

Reference: INSPECTION USING OSCILLOSCOPE

- With the engine racing (4,000 rpm), check the waveform between terminal KNK of the ECM connector and body ground.

HINT:

The correct waveform is as shown.

- Spread the time on the horizontal axis, and confirm that period of the wave is 0.151 msec. (Normal mode vibration frequency of knock sensor: 6.6 kHz).

HINT:

If normal mode vibration frequency is not 6.6 kHz the sensor malfunctions or ECM (terminal KNK).

OK → Go to step 3.

NG

2 Check knock sensor (See page [SF-49](#)).

NG → Replace knock sensor.

OK

3 Check for open and short in harness and connector between ECM and knock sensor (See page [IN-28](#)).

NG → Repair or replace harness or connector.

OK

4	Does malfunction disappear when good knock sensor is installed? 
----------	--

YES	Replace knock sensor.
------------	------------------------------

NO

Check and replace ECM (See page IN-28).
--