

REPLACEMENT

1. REPLACE CONNECTING ROD BUSHINGS

- (a) Using SST and a press, press out the bushing.
SST 09222-30010

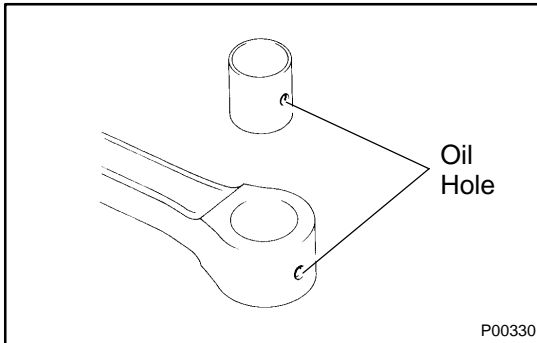

- (b) Align the oil holes of a new bushing and the connecting rod.

- (c) Using SST and a press, press in the bushing.
SST 09222-30010

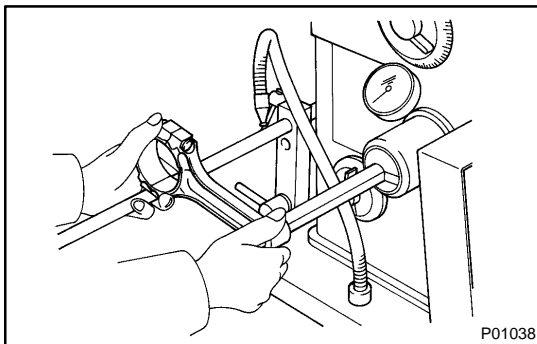

- (d) Using a pin hole grinder, hone the bushing to obtain the standard specified clearance (See page EM-88) between the bushing and piston pin.

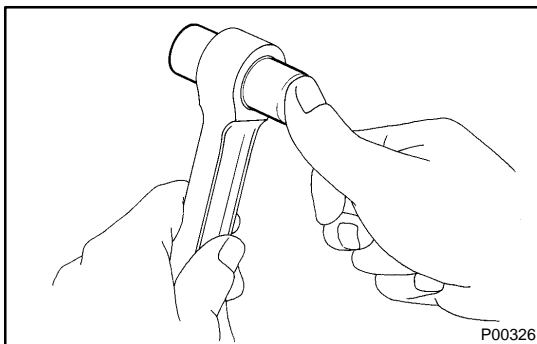

- (e) Check the piston pin fit at normal room temperature. Coat the piston pin with engine oil, and push it into the connecting rod with your thumb.

2. REPLACE OVERSIZED (O/S) PISTONS

HINT:

- Bore all the 6 cylinders for the O/S piston outside diameter.
- Replace all the piston rings with ones to match the O/S pistons.

- (a) Keep 6 new O/S pistons.

O/S 0.50 piston diameter:

93.856 – 93.886 mm (3.6951 – 3.6963 in.)

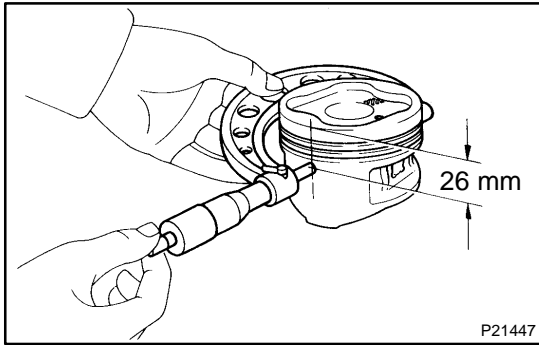

(b) Using a micrometer, measure the piston diameter at right angles to the piston pin center line, 26 mm (1.02 in.) from the piston head.

(c) Calculate the amount of each cylinder is to be rebored as follows:

$$\text{Size to be rebored} = P + C - H$$

P = Piston diameter

C = Piston oil clearance:

0.134 – 0.154 mm (0.0053 – 0.0060 in.)

H = Allowance for honing:

0.02 mm (0.0008 in.) or less

(d) Bore and hone cylinder to calculated dimensions

Maximum honing: 0.02 mm (0.0008 in.)

NOTICE:

Excess honing will destroy the finished roundness.

3. REPLACE CRANKSHAFT FRONT OIL SEAL

(See page [LU-12](#))

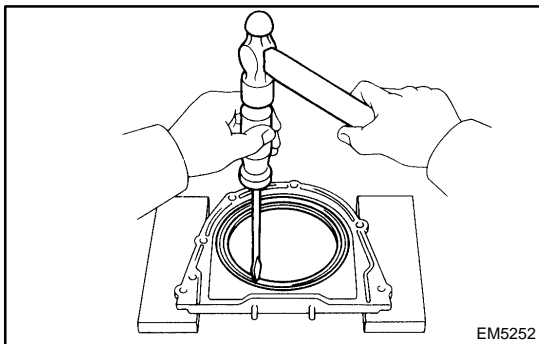

4. REPLACE CRANKSHAFT REAR OIL SEAL

HINT:

There are 2 methods ((a) and (b)) to replace the oil seal.

(a) If rear oil seal retainer is removed from the cylinder block:

(1) Using a screwdriver and hammer, tap out the oil seal.

(2) Using SST and a hammer, tap in a new oil seal until its surface is flush with the rear oil seal retainer edge.

SST 09223-15030, 09950-70010 (09951-07150)

(3) Apply MP grease to the oil seal lip.

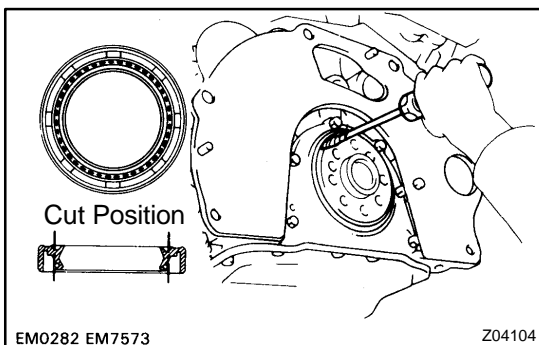
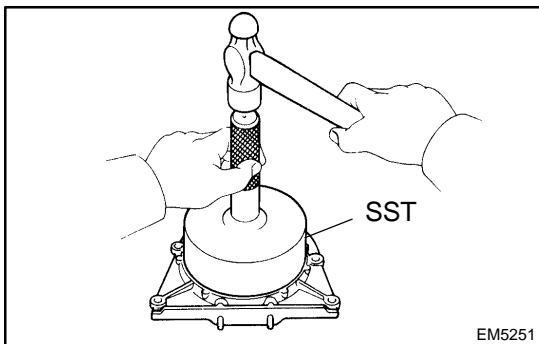

(b) If rear oil seal retainer is installed to the cylinder block:

(1) Using a knife, cut off the oil seal lip.

(2) Using a screwdriver, pry out the oil seal.

NOTICE:

Be careful not to damage the crankshaft. Tape the screwdriver tip.

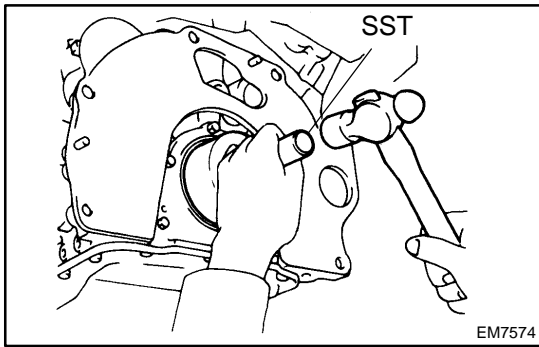

- (3) Apply MP grease to a new oil seal lip.
 - (4) Using SST and a hammer, tap in the oil seal until its surface is flush with the rear oil seal retainer edge.
- SST 09923-15030, 09950-70010 (09951-07150)