

DISASSEMBLY

1. **REMOVE BACK-UP LIGHT SWITCH**
Torque: 44 N·m (450 kgf-cm, 32 ft-lbf)

2. **2WD:**

REMOVE VEHICLE SPEED SENSOR

Remove the bolt and vehicle speed sensor.

Torque: 11 N·m (115 kgf-cm, 8 ft-lbf)

3. **REMOVE CLUTCH HOUSING FROM TRANSMISSION CASE**

Remove the 9 bolts and clutch housing from the transmission case.

Torque: 36 N·m (370 kgf-cm, 27 ft-lbf)

4. **REMOVE CONTROL SHIFT LEVER RETAINER**

- (a) Remove the 6 (2WD) or 4 (4WD) bolts.

Torque: 18 N·m (185 kgf-cm, 13 ft-lbf)

- (b) Remove the retainer and gasket (2WD) or oil deflector (4WD).

5. **REMOVE 2 RESTRICT PINS**

Torque: 37 N·m (380 kgf-cm, 27 ft-lbf)

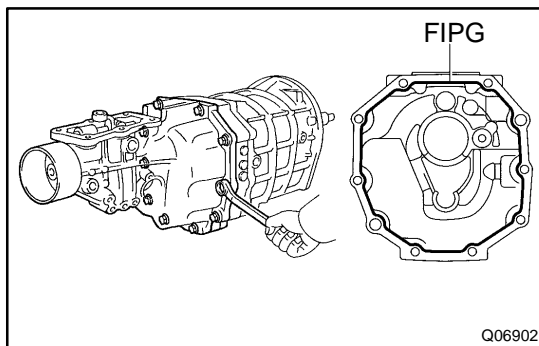

6. **2WD:**

REMOVE EXTENSION HOUSING

- (a) Remove the shift lever housing set bolt.

Torque: 38 N·m (390 kgf-cm, 28 ft-lbf)

- (b) Remove the 10 bolts.

Torque: 37 N·m (380 kgf-cm, 27 ft-lbf)

- (c) Using a plastic hammer, tap the extension housing, remove the shift lever housing and shift and select lever.

FIPG:

Part No. 08826-00090, THREE BOND 1281 or equivalent

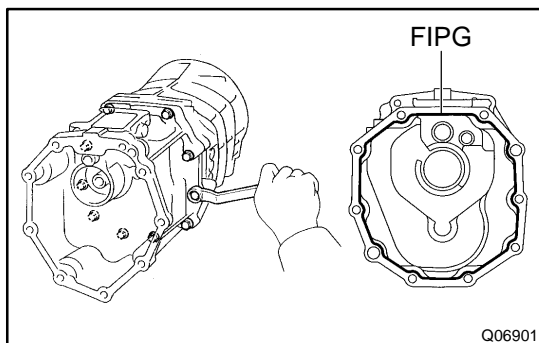

7. **4WD:**

REMOVE TRANSFER ADAPTOR

- (a) Remove the shift lever housing set bolt.

Torque: 38 N·m (390 kgf-cm, 28 ft-lbf)

- (b) Remove the 10 bolts.

Torque: 37 N·m (380 kgf-cm, 27 ft-lbf)

- (c) Using a plastic hammer, tap the transfer adaptor, remove the shift lever housing and the shift and select lever.

FIGP:

Part No. 08826-00090, THREE BOND 1281 or equivalent

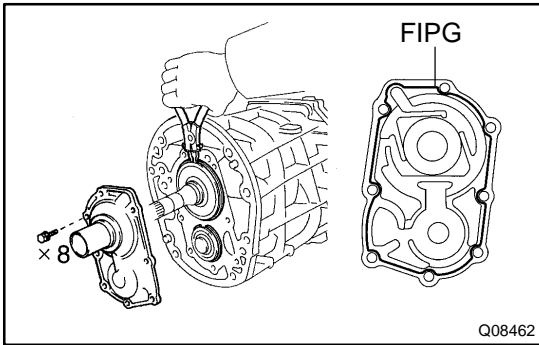

8. REMOVE FRONT BEARING RETAINER

- (a) Remove the 8 bolts.

Sealant:

Part No.08833-00080, THREE BOND 1344, LOCTITE 242 or equivalent

Torque: 17 N·m (170 kgf·cm, 12 ft·lbf)

- (b) Using a plastic hammer, tap the front bearing retainer.

FIGP:

Part No. 08826-00090, THREE BOND 1281 or equivalent

9. REMOVE BEARING SNAP RING

Using a snap ring expander, remove the 2 snap rings.

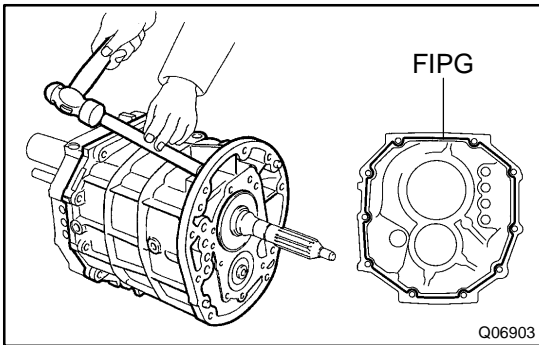

10. SEPARATE INTERMEDIATE PLATE FROM TRANSMISSION CASE

- (a) Using a brass bar and hammer, carefully tap the transmission case.
- (b) Remove the transmission case from the intermediate plate.

HINT:

At the time of reassembly, please refer to the following item. Align the each bearing outer race, each fork shaft end and reverse idler gear shaft end with the case installation holes.

FIGP:

Part No. 08826-00090, THREE BOND 1281 or equivalent

11. REMOVE MAGNET FROM INTERMEDIATE PLATE

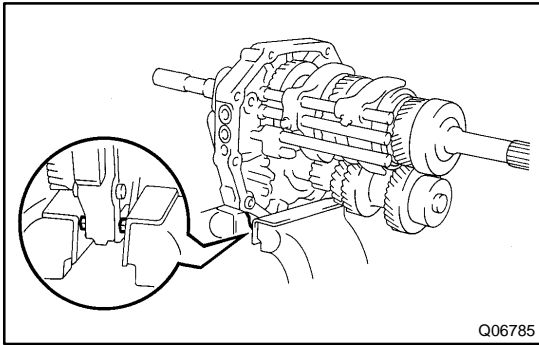

12. MOUNT INTERMEDIATE PLATE IN VISE

- (a) Use the 2 clutch housing bolts, plate washers and suitable nuts, as shown.

HINT:

Increase or decrease plate washers so that the bolt tip does not protrude from the nut.

- (b) Mount the intermediate plate in a vise.

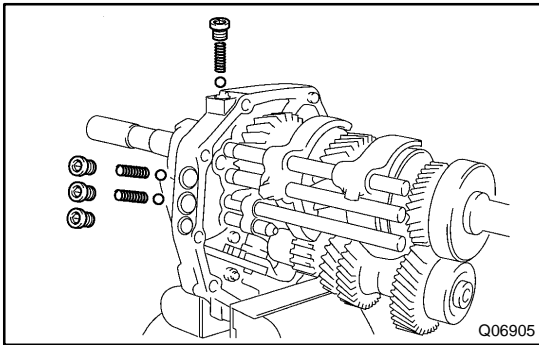

13. REMOVE STRAIGHT SCREW PLUG, LOCKING BALL AND SPRING

- (a) Using a hexagon wrench, remove the 4 plugs.

Sealant:

Part No.08833-00080, THREE BOND 1344, LOCTITE 242 or equivalent

Torque: 19 N·m (190 kgf·cm, 14 ft·lbf)

- (b) Using a magnetic finger, remove the 3 springs and balls.

14. REMOVE SHIFT FORK SET BOLT

Remove the 2 bolts from the shift forks No.1 and No.2.

Torque: 20 N·m (200 kgf·cm, 14 ft·lbf)

15. REMOVE SLOTTED SPRING PIN

Using a pin punch and hammer, drive out the pin from the shift fork No.3.

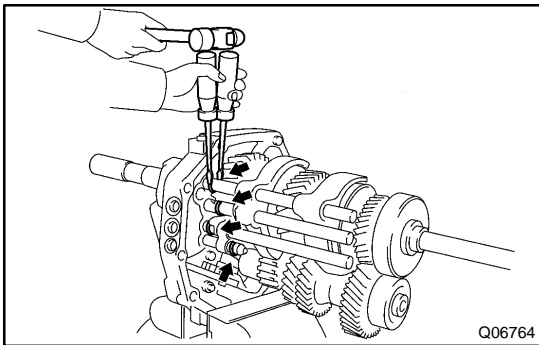

16. REMOVE SNAP RING

Using 2 screwdrivers and a hammer, tap out the 4 snap rings from each shift fork shaft.

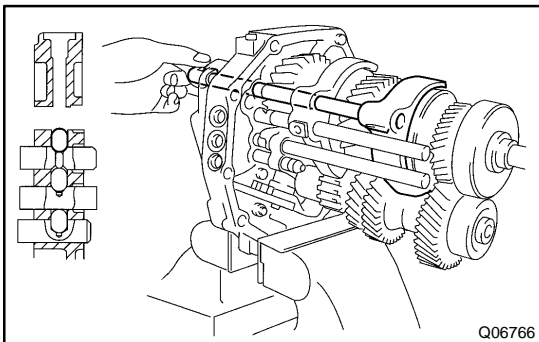

17. REMOVE SHIFT FORK SHAFT NO.2 AND SHIFT FORK NO.2

- (a) Pull out the shift fork shaft No.2 from the shift forks No.1, No.2 and intermediate plate.

- (b) Remove the shift fork No.2 from the groove of hub sleeve No.2.

- (c) Using a magnetic finger, remove the interlock pin from the intermediate plate.

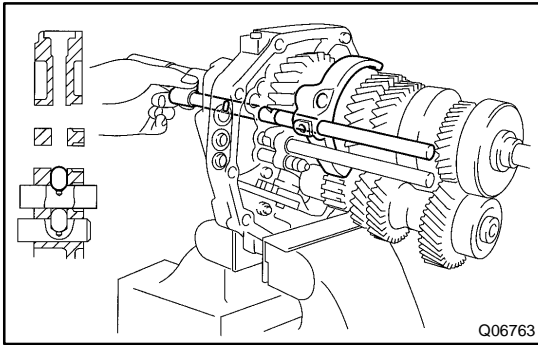

18. REMOVE SHIFT FORK SHAFT NO.1 AND SHIFT FORK NO.1

- (a) Pull out the shift fork shaft No.1 with the straight pin from the shift fork No.1 and intermediate plate.
- (b) Remove the shift fork No.1 from the groove of reverse gear.
- (c) Using a magnetic finger, remove the interlock pin from the intermediate plate.

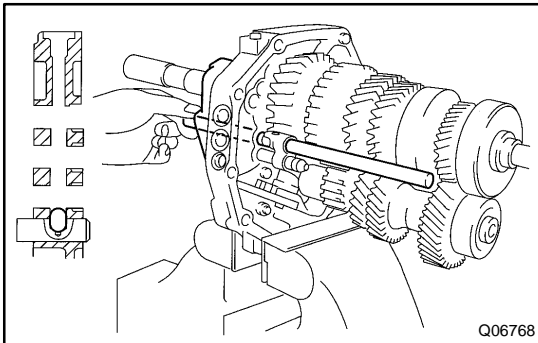

19. REMOVE SHIFT FORK SHAFT NO.3 AND SHIFT FORK NO.3

- (a) Pull out the shift fork shaft No.3 from the shift fork No.3, reverse shift fork and intermediate plate.
- (b) Remove the shift fork No.3 from the groove of hub sleeve No.3.
- (c) Using a magnetic finger, remove the interlock pin from the intermediate plate.

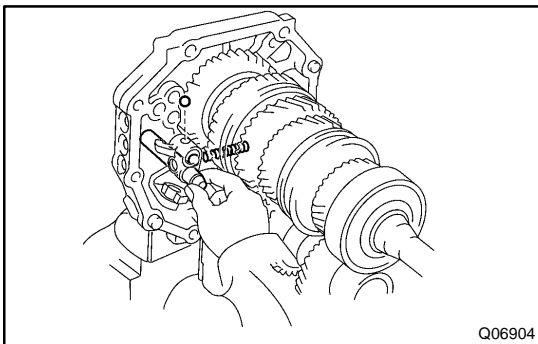

20. REMOVE SHIFT FORK SHAFT NO.4

- (a) Using a magnetic finger, remove the ball.
- (b) Pull out the shift fork shaft No.4 from the reverse shift fork and intermediate plate.

NOTICE:

Take care of the ball in the reverse shift fork. It will spring out when you pull out the shift fork shaft No.4.

- (c) Using a magnetic finger, remove the spring from the reverse shift fork.

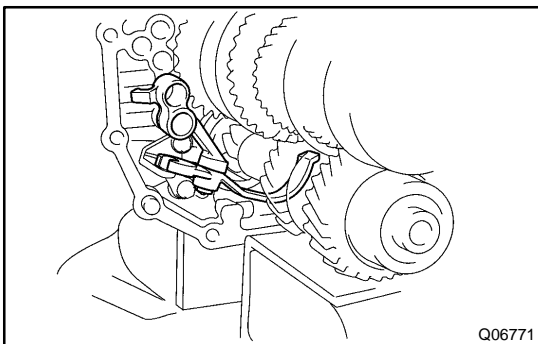

21. REMOVE REVERSE SHIFT FORK AND ARM

- (a) Remove the reverse shift fork and arm.

HINT:

At the time of reassembly, please refer to the following item. Align the reverse shift arm to the pivot of the reverse shift arm bracket.

- (b) Using a screwdriver, remove the E-ring.
- (c) Separate the reverse shift fork and arm.

22. REMOVE REVERSE SHIFT ARM BRACKET

Remove the 2 bolts and reverse shift arm bracket.

Torque: 18 N·m (185 kgf-cm, 13 ft-lbf)

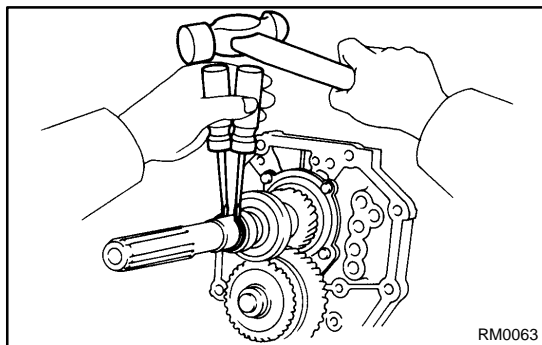

23. 2WD:

REMOVE VEHICLE SPEED SENSOR DRIVE GEAR

- (a) Using 2 screwdrivers and a hammer, tap out the rear snap ring, and remove the drive gear and ball.
- (b) Using 2 screwdrivers and a hammer, tap out the front snap ring, and remove the drive gear.

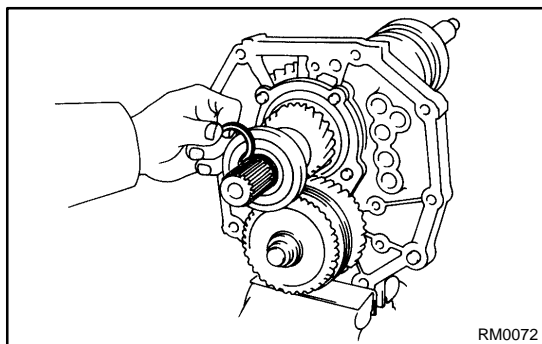

24. REMOVE OUTPUT SHAFT REAR BEARING

- (a) Using 2 screwdrivers and a hammer, tap out the snap ring.

HINT:

At the time of reassembly, please refer to the following item. Select a snap ring that allows the minimum axial play.

Mark	Thickness mm (in.)
A	2.65 – 2.70 (0.1043 – 0.1063)
B	2.70 – 2.75 (0.1063 – 0.1083)
C	2.75 – 2.80 (0.1083 – 0.1102)
D	2.80 – 2.85 (0.1102 – 0.1122)
E	2.85 – 2.90 (0.1122 – 0.1142)
F	2.90 – 2.95 (0.1142 – 0.1161)
G	2.95 – 3.00 (0.1161 – 0.1181)
H	3.00 – 3.05 (0.1181 – 0.1201)
J	3.05 – 3.10 (0.1201 – 0.1220)
K	3.10 – 3.15 (0.1220 – 0.1240)
L	3.15 – 3.20 (0.1240 – 0.1260)
M	3.20 – 3.25 (0.1260 – 0.1280)
N	3.25 – 3.30 (0.1280 – 0.1299)
P	3.30 – 3.35 (0.1299 – 0.1319)
Q	3.35 – 3.40 (0.1319 – 0.1339)
R	3.40 – 3.45 (0.1339 – 0.1358)
S	3.45 – 3.50 (0.1358 – 0.1378)

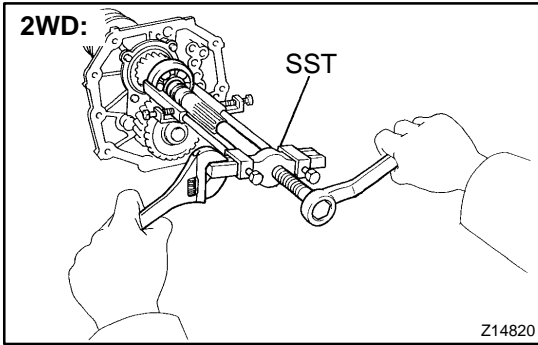

- (b) Using SST, remove the rear bearing.
SST 09950-40011

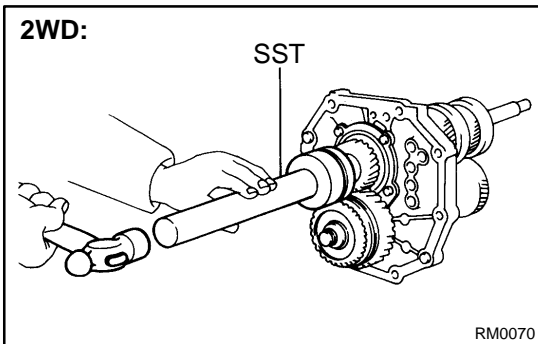
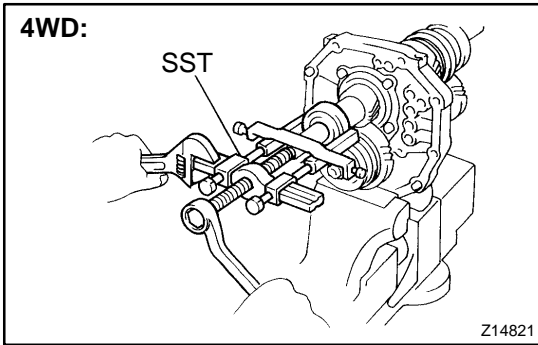

HINT:

At the time of reassembly, please refer to the following items.

- 2WD:
Using SST and a hammer, drive in a new bearing.
SST 09309-35010

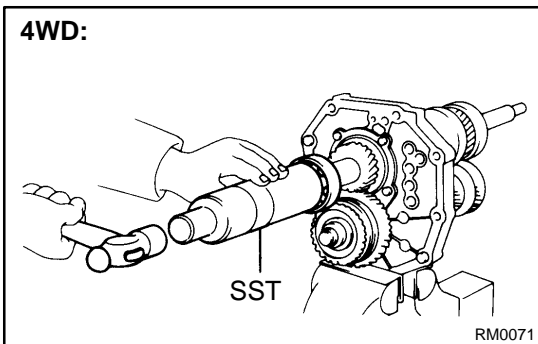

- 4WD:
Using SST and a hammer, drive in a new bearing.
SST 09316-60011 (09316-00011, 09316-00071)

25. REMOVE SPACER

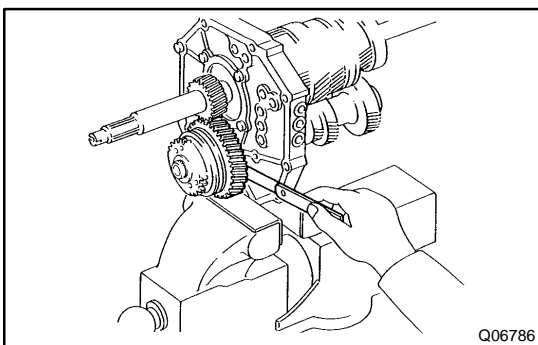

26. INSPECT COUNTER 5TH GEAR THRUST CLEARANCE

Using a feeler gauge, measure the counter 5th gear thrust clearance.

- Standard clearance:**
0.10 – 0.35 mm (0.0039 – 0.0138 in.)
- Maximum clearance:**
0.40 mm (0.0157 in.)

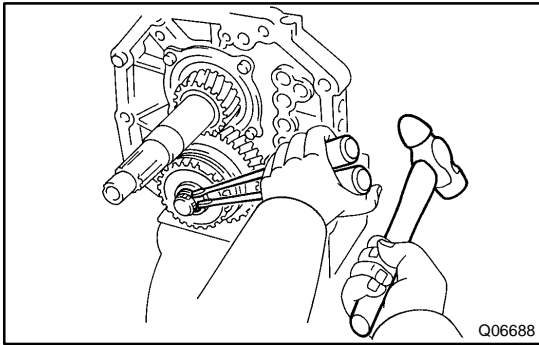

27. REMOVE GEAR SPLINE PIECE NO.5, SYNCHRONIZER RING, NEEDLE ROLLER BEARING AND COUNTER 5TH GEAR WITH HUB SLEEVE NO.3

- (a) Using 2 screwdrivers and a hammer, tap out the snap ring.

HINT:

At the time of reassembly, please refer to the following item. Select a snap ring that allows the minimum axial play.

Mark	Thickness mm (in.)
A	2.80 – 2.85 (0.1102 – 0.1122)
B	2.85 – 2.90 (0.1122 – 0.1142)
C	2.90 – 2.95 (0.1142 – 0.1161)
D	2.95 – 3.00 (0.1161 – 0.1181)
E	3.00 – 3.05 (0.1181 – 0.1201)
F	3.05 – 3.10 (0.1201 – 0.1220)
G	3.10 – 3.15 (0.1220 – 0.1240)

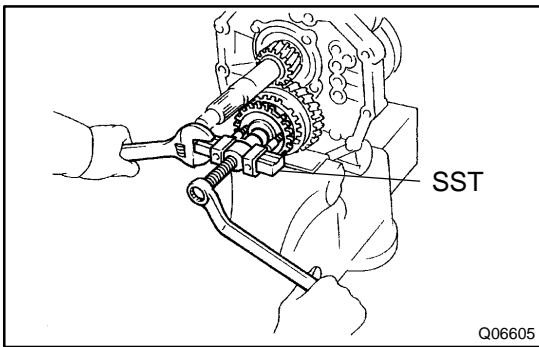

- (b) Using SST, remove the gear spline piece No.5.
SST 09950-50013
- (c) Remove the counter 5th gear with the hub sleeve No.3.

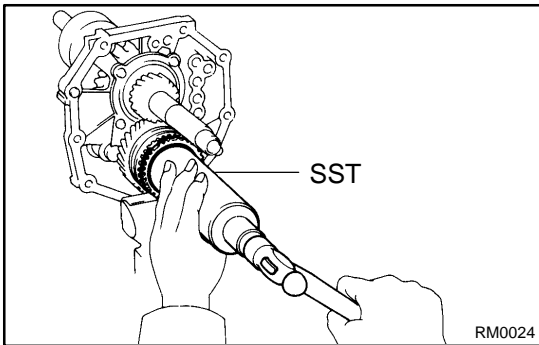

HINT:

At the time of reassembly, please refer to the following items.

- Using SST and a hammer, drive in the gear spline piece No.5 with the synchronizer ring slots aligned with the shifting keys.
SST 09316-60011 (09316-00011)
- When installing the gear spline piece No.5, support the counter gear in front with a 1.4 – 2.3 kg (3 – 5 lb) hammer or equivalent.

28. REMOVE THRUST WASHER AND BALL FROM COUNTER GEAR

29. REMOVE REAR BEARING RETAINER

Remove the 4 bolts and rear bearing retainer.

HINT:

At the time of reassembly, please refer to the following item. Align the rear bearing retainer to the reverse idler gear shaft groove.

Torque: 18 N·m (185 kgf·cm, 13 ft·lbf)

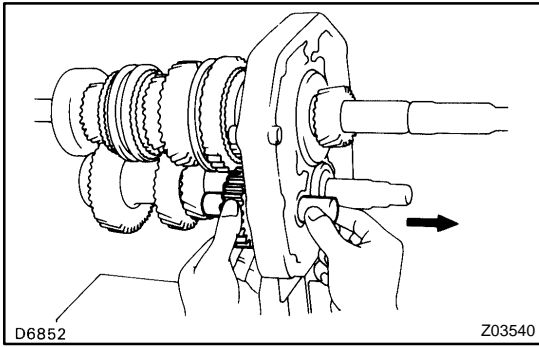

30. REMOVE REVERSE IDLER GEAR AND SHAFT

Pull out the shaft toward the rear.

HINT:

At the time of reassembly, please refer to the following item.
Align the reverse shift arm to the reverse idler gear shaft.

31. REMOVE OUTPUT SHAFT CENTER BEARING SNAP RING

Using a snap ring expander, remove the snap ring.

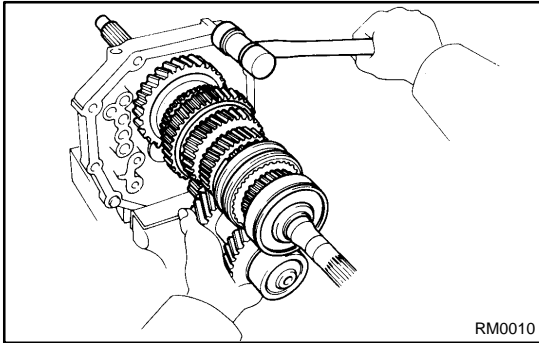

32. REMOVE OUTPUT SHAFT AND COUNTER GEAR FROM INTERMEDIATE PLATE

- (a) Remove the output shaft, counter gear and input shaft as a unit from the intermediate plate by pulling on the counter gear and tapping on the intermediate plate with a plastic hammer.
- (b) Remove the input shaft with the needle roller bearing from the output shaft.

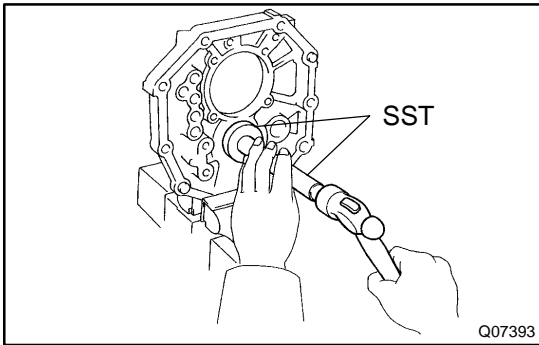

33. REMOVE COUNTER REAR BEARING FROM INTERMEDIATE PLATE

Using SST and a hammer, remove the counter rear bearing.

SST 09950-60010 (09951-00620), 09950-70010 (09951-07150)