

REMOVAL

1. **REMOVE FRONT WHEEL**
Torque: 110 N·m (1,150 kgf·cm, 83 ft·lbf)
2. **REMOVE SHOCK ABSORBER** (See page SA-76)
3. **4WD:**
DISCONNECT DRIVE SHAFT

(a) Using a screwdriver, remove the grease cap.

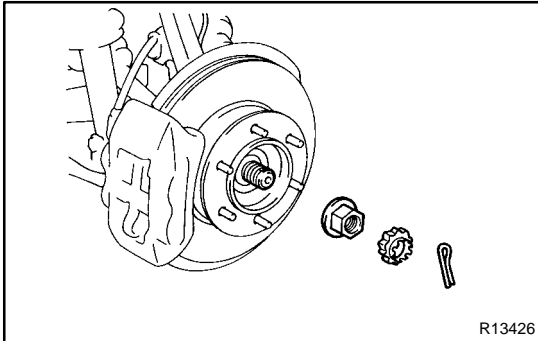

(b) Remove the cotter pin and lock cap.

HINT:

At the time of installation, if the holes for the cotter pin are not aligned, tighten the nut further up to 60°.

(c) With applying the brakes, remove the lock nut.

Torque: 235 N·m (2,400 kgf·cm, 174 ft·lbf)

4. **w/ ABS:**

DISCONNECT ABS SPEED SENSOR AND WIRE HARNESS CLAMP FROM STEERING KNUCKLE

Remove the 2 bolts and ABS speed sensor wire harness clamp from the steering knuckle.

Torque: 8.0 N·m (82 kgf·cm, 71 in.-lbf)

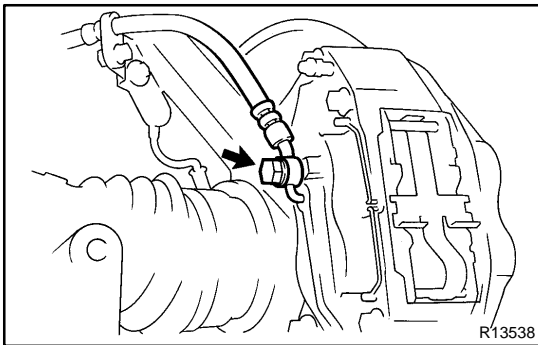

5. **REMOVE BRAKE CALIPER AND DISC**

(a) Remove the union bolt and 2 gaskets from the caliper, then disconnect the flexible hose from the caliper.

Torque: 30 N·m (310 kgf·cm, 22 ft·lbf)

HINT:

At the time of installation, install the flexible hose lock securely in the lock hole in the caliper.

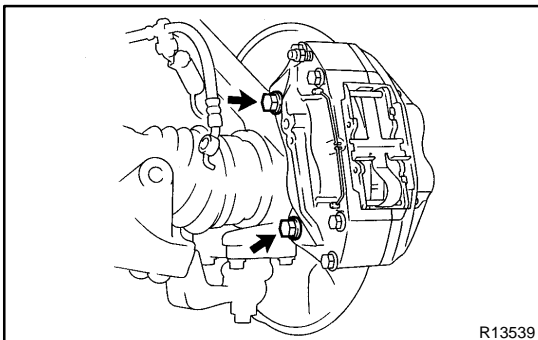

(b) Remove the 2 bolts, brake caliper and disc.

Torque: 123 N·m (1,250 kgf·cm, 90 ft·lbf)

(c) Support the brake caliper securely.

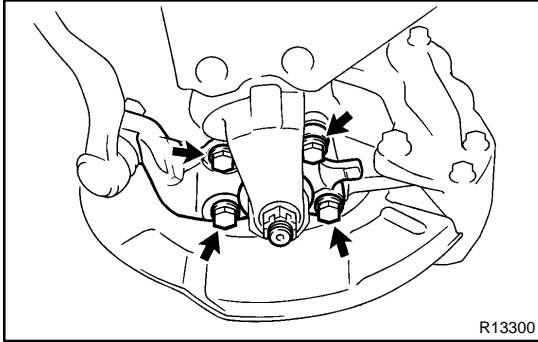
**6. DISCONNECT LOWER BALL JOINT**

Remove the 4 bolts and disconnect the lower ball joint.

Torque: 80 N·m (820 kgf·cm, 59 ft·lbf)

7. REMOVE STEERING KNUCKLE

(a) Remove the cotter pin and loosen the nut.

Torque: 105 N·m (1,100 kgf·cm, 80 ft·lbf)

HINT:

At the time of installation, if the holes for the cotter pin are not aligned, tighten the nut further up to 60°.

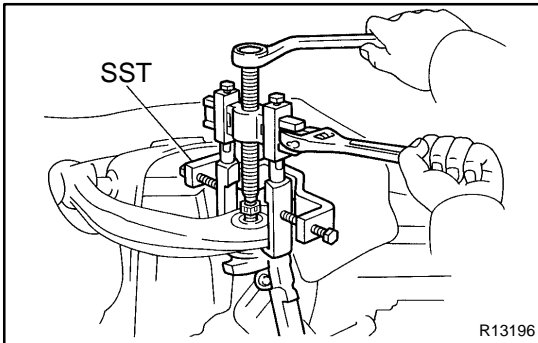

(b) Using SST, disconnect the steering knuckle.

SST 09950-40011 (09951-04010, 09952-04010, 09553-04020, 09554-04010, 09955-04031, 09958-04011)

(c) Remove the nut and steering knuckle.

NOTICE:

4WD:

Be careful not to damage the oil seal and drive shaft boot.

HINT:

4WD:

When it is difficult to disconnect the drive shaft, tap the tip of the drive shaft with a plastic hammer.