

## FUEL CUT RPM INSPECTION

SF10M-03

### 1. WARM UP ENGINE

Allow the engine to warm up to normal operating temperature.

### 2. CONNECT TOYOTA HAND-HELD TESTER OR OBDII SCAN TOOL (See page SF-1)

### 3. INSPECT FUEL CUT OFF RPM

(a) Increase the engine speed to at least 3,500 rpm.

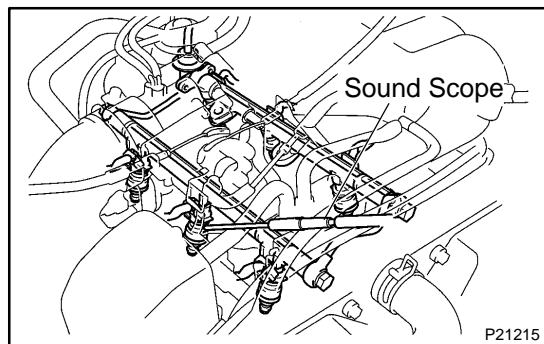

(b) Use a sound scope to check for injector operating noise.

(c) Check that when the throttle lever is released, injector operation noise stops momentarily and then resumes.

#### HINT:

Measure with the A/C OFF.

#### Fuel return rpm:

M/T	1,000 rpm
A/T	1,200rpm

### 4. DISCONNECT TOYOTA HAND-HELD TESTER OR OBDII SCAN TOOL