

INSPECTION

1. INSPECT PINION GEAR THRUST CLEARANCE

Using a feeler gauge, measure the planetary pinion gear thrust clearance.

Standard clearance:

0.11 – 0.84 mm (0.0043 – 0.0331 in.)

Maximum clearance: 0.84 mm (0.0331 in.)

If the clearance exceeds the maximum, replace the planetary gear assembly.

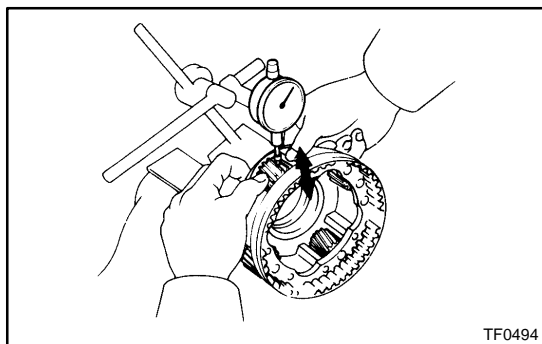

2. INSPECT PLANETARY PINION GEAR RADIAL CLEARANCE

Using a dial indicator, measure the radial clearance of the planetary pinion gear.

Standard clearance:

0.009 – 0.038 mm (0.0004 – 0.0015 in.)

Maximum clearance: 0.038 mm (0.0015 in.)

If the clearance exceeds the maximum, replace the planetary gear assembly.

3. IF NECESSARY, REPLACE PLANETARY GEAR OUTER BEARING

(a) Using a snap ring expander, remove the snap ring.

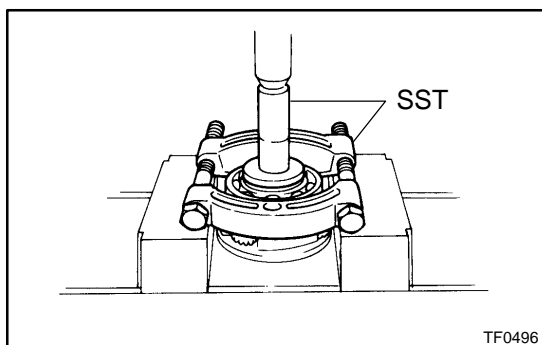

(b) Using SST and a press, remove the bearing.
SST 09554-30011, 09555-55010

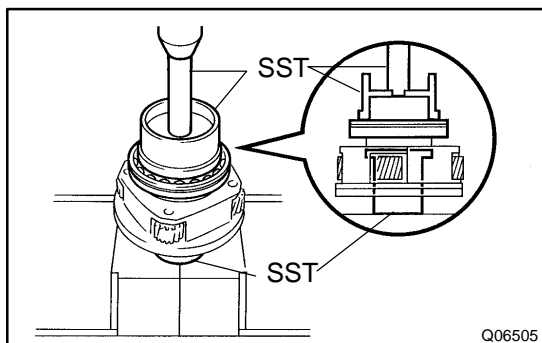

(c) Using SST and a press, install a new bearing with the groove faced forward.
SST 09223-15020, 09515-30010,
09950-70010 (09951-07100)

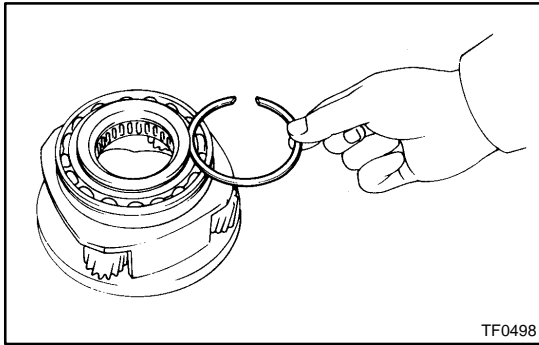

(d) Select a snap ring that will allow minimum axial play.

Mark	Thickness mm (in.)
1	1.45 - 1.50 (0.0571 - 0.0591)
2	1.50 - 1.55 (0.0591 - 0.0610)
3	1.55 - 1.60 (0.0610 - 0.0630)
4	1.60 - 1.65 (0.0630 - 0.0650)
5	1.65 - 1.70 (0.0650 - 0.0669)

(e) Using a snap ring expander, install the snap ring.

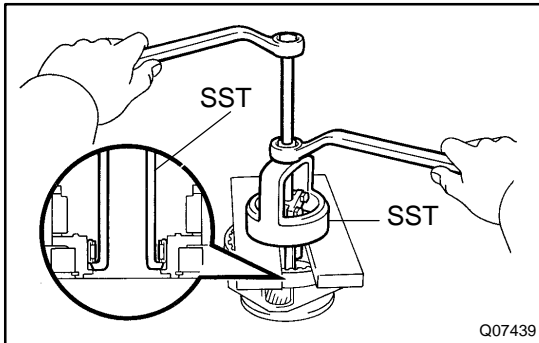

4. IF NECESSARY, REPLACE PLANETARY GEAR THRUST INNER BEARING

(a) Using SST and a press, remove the bearing.

SST 09612-65014 (09612-01030, 09612-01050)

NOTICE:

Hang SST securely to the clearance between the thrust inner bearing and planetary gear.

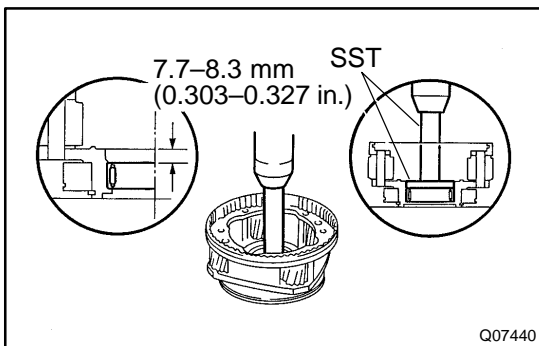

(b) Using SST and a press, install a new bearing.

SST 09950-60010 (09951-00570),

09950-70010 (09951-07100)

Bearing depth: 7.7 - 8.3 mm (0.303 - 0.327 in.)